

The World's Most Trusted Industrial Torque and Tension Systems

jGun™ Wheel Bolting

Custom extension for wheel bolt removal.

Extensions sold separately, available in 7", 9" and 12"



- Quick Shift from Torque to Speed Mode
- Silent and Vibration Free Operation
- High Speed Rundown & Final Torque
- Maximum torque requires only 90 psi
- Powerful Nut Loosening / Ultra Fast Nut Removal
- Made from Lightweight High-Strength Aluminum Alloy
- Precision Gearing Produces Constant, Calibrated Power
- Eliminates the Need to use Impact Guns for Pre-Torquing
- Highest Power-to-Weight Ratio of any Comparable Product



OPTIONAL PATENTED SAFETY LEVER

This safety mechanism drastically reduces operator error. The lever must be depressed while pulling the trigger, ensuring operator keeps hands away from pinch points.



24 Hour SERVICE

888-GUN-2-GUN

www.torquegun.com

— THE —
TORQUE GUN™
— COMPANY —

120 WESLEY ST., SO. HACKENSACK NJ 07606

ACCESSORIES



AIR DRYER

Air dryer eliminates moisture from the air supply in high volume.
No manual purging



FRL UNIT

Filter, Regulator and Lubrication Unit. For use with all torque guns. Optional Silencer Unit to reduce operational noise by 35%, down to a very low 70-75 Db.



Standard - 6 Point

Standard - 12 Point

Castellated

TORQUE IMPACT SOCKETS

Impact and torque assert different stress loads to sockets. The TorCimpact™ sockets from the TORQUE GUN Company come in all sizes and configurations. The difference is Quality and instant availability.

DIMENSIONAL DATA

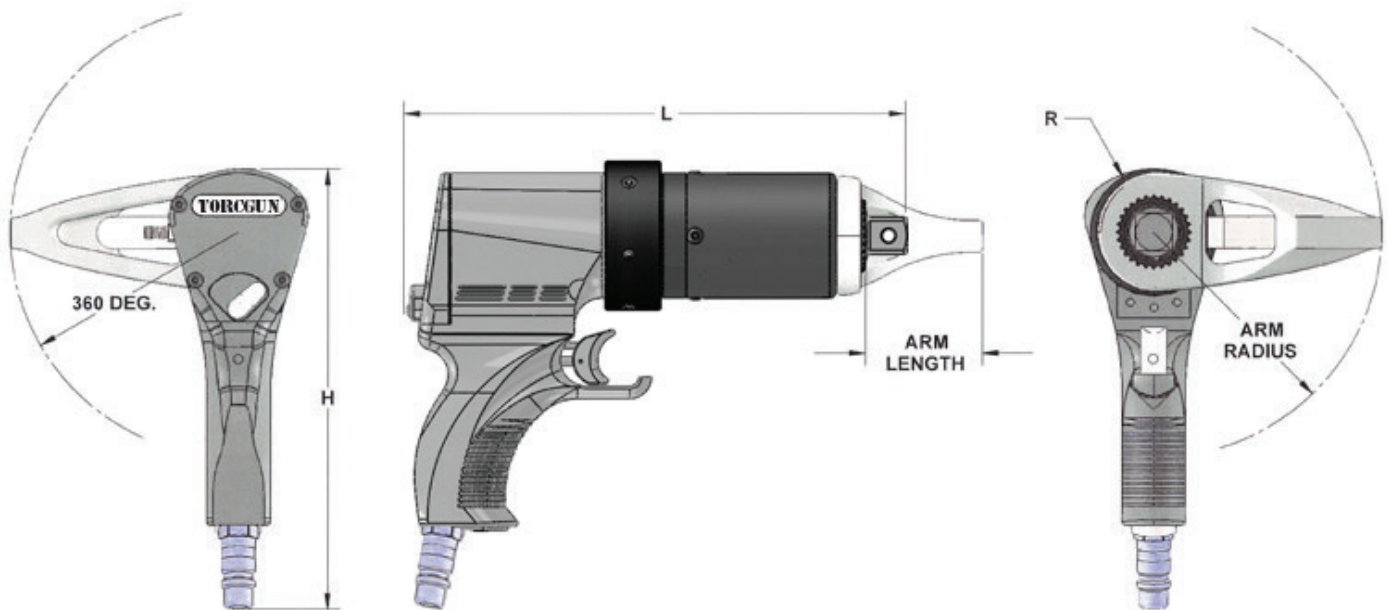

	Torque Range	Drive	Bolt Sizes	H	L	R	Arm Length	Arm Radius	RPM	Rundown RPM	Weight w/o Arm	Weight w/ Arm
Model	Ft. Lbs./Nm			Inches/cm							Lbs./Kg	
J-A1-AP-WG	255-1075/346-1457	¾"	7/8" to 1 3/8"	7.70/19.50	11.21/28.47	1.50/3.81	3.30/8.38	5.25/13.34	12	225	12.0/5.4	13.2/6.0
J-A3-AP-WG	915-3305/1240-4481	1"	1 ¼" to 1 7/8"	7.34/18.60	12.35/31.37	1.81/4.60	3.83/9.73	5.85/14.68	8.5	150+	12.0/5.4	15.35/7.0